

Harcourts Kingsberry



14 Burramugga Crescent Kirwan QLD

4 1 1

Centrally located on a 615sqm block only minutes to Schools, Shops, Public Transport this property offers a great entry level into the Townsville property market, or an investment opportunity packed with potential.

The masonry block residence offers great internal proportions and a very functional layout. The house needs some cosmetic works to bring it up to speed but has the potential to be a great home/ investment property for decades to come.

Property Features:

- Four bedrooms with built-in robes and air-conditioning
- Original carport has been enclosed to offer walk-in robe/ multipurpose room located off the master bedroom
- Main bathroom features large walk-in shower with separate toilet

Price : \$ 289,000
Land Size : 615 sqm
View : <https://www.kingsberry.com.au/sale/qld/townsville-district/kirwan/residential/house/7269708>



Adrian Raiteri
07 4772 2022
0427 673 612
adrian.raiteri@tsvharcourts.com.au

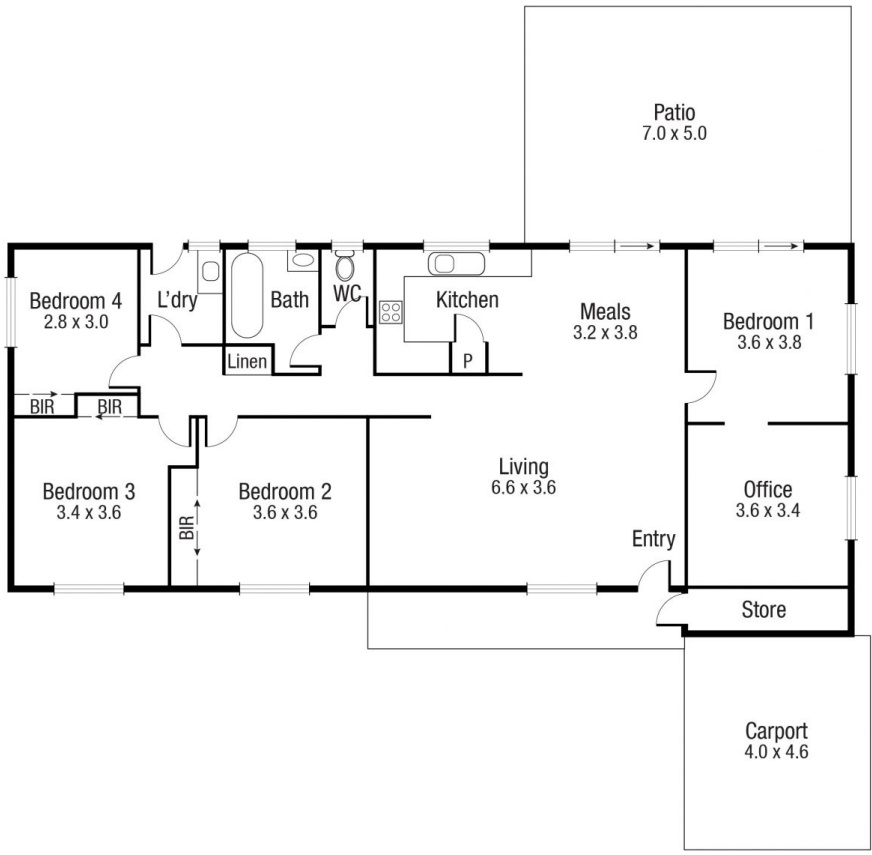

Scale in metres. Indicative only. Dimensions are approximate. All information contained herein is gathered from sources we believe to be reliable. However we cannot guarantee its accuracy and interested persons should rely on their own enquiries.

TOTAL AREA : 189.9 sq.m

14 BURRAMUGGA